



Kendall

HDEO PRODUCTS

HARD WORK. DONE RIGHT.



Kendall
LIQUID TITANIUM
PROTECTION ADDITIVE

SHP

CK-4

DIESEL ENGINE OIL
HUILE DE MOTEUR DIESEL
ACEITE DE MOTORES DIESEL

Advanced Cold Flow
Flux Froid Avancé
Flujo Frío Avanzado

FULL SYNTHETIC | TOTALMENTE SINTÉTICO | ENTIÈREMENT SYNTHÉTIQUE

SAE **5W-40**

1 U.S. GALLON (3.785 LITERS)

Kendall
LIQUID TITANIUM
PROTECTION ADDITIVE

SUPER-D FE

FA-4

DIESEL ENGINE OIL
HUILE DE MOTEUR DIESEL
ACEITE DE MOTORES DIESEL

Advanced Fuel Economy
Economie de Carburant Avancée
Ahorro de Combustible Avanzado

SYNTHETIC BLEND | MÉLANGE SYNTHÉTIQUE | MEZCLA SINTÉTICA

SAE **10W-30**

1 U.S. GALLON (3.785 LITERS)

Kendall
LIQUID TITANIUM
PROTECTION ADDITIVE

SUPER-DXA

CK-4

DIESEL ENGINE OIL
HUILE DE MOTEUR DIESEL
ACEITE DE MOTORES DIESEL

Advanced Wear Control
Contrôle Avancé de L'usure
Control de Desgaste Avanzado

SYNTHETIC BLEND | MÉLANGE SYNTHÉTIQUE | MEZCLA SINTÉTICA

SAE **10W-30**

1 U.S. GALLON (3.785 LITERS)





To get the most out of your heavy-duty engines, you have to be prepared for whatever the job throws at you. Whether you spend your days chasing long white lines, moving the earth or tilling the land for next season's crop, we've put in hours of real-life testing to ensure your equipment receives superior protection. We've updated our formulations to exceed CK-4 and FA-4 standards. Our low viscosity options offer the same protection with even better performance. So, if you're like us and believe any job worth doing should be done right, consider pouring Kendall into your heavy-duty engines for a longer, stronger life.

TRUCKING

ENGINE

A DIESEL

Fuel economy options

Super-D® FE 10W-30 with Liquid Titanium® protection additive

API FA-4 diesel engine oil.

SHP® FE 5W-30

API FA-4 diesel engine oil.

Premium synthetic blend option

Super-D XA® with Liquid Titanium protection additive

API CK-4 diesel engine oil.

Full synthetic options

SHP 5W-40 with Liquid Titanium protection additive

API CK-4 diesel engine oil.

SHP Euro 5W-30

API CK-4 diesel engine oil.

Mainline option

Super-D EC

API CK-4 diesel engine oil.

CNG/LNG

Premium option

Super-D NG

Premium oil for slider-follower diesel engines converted to natural-gas service.

B MANUAL STEERING GEAR

Premium option

SHP Synthetic Gear Lube or Super Three Star® Synthetic Gear Lubricant

Synthetic multipurpose gear lubricants for truck axles with hypoid gear sets operating in normal to severe conditions.

Mainline option

NS-MP Hypoid Gear Lubricant

Multipurpose gear lubricant, API GL-5/MT-1, for differentials operating in varying conditions of speed, load, temperature and torque.

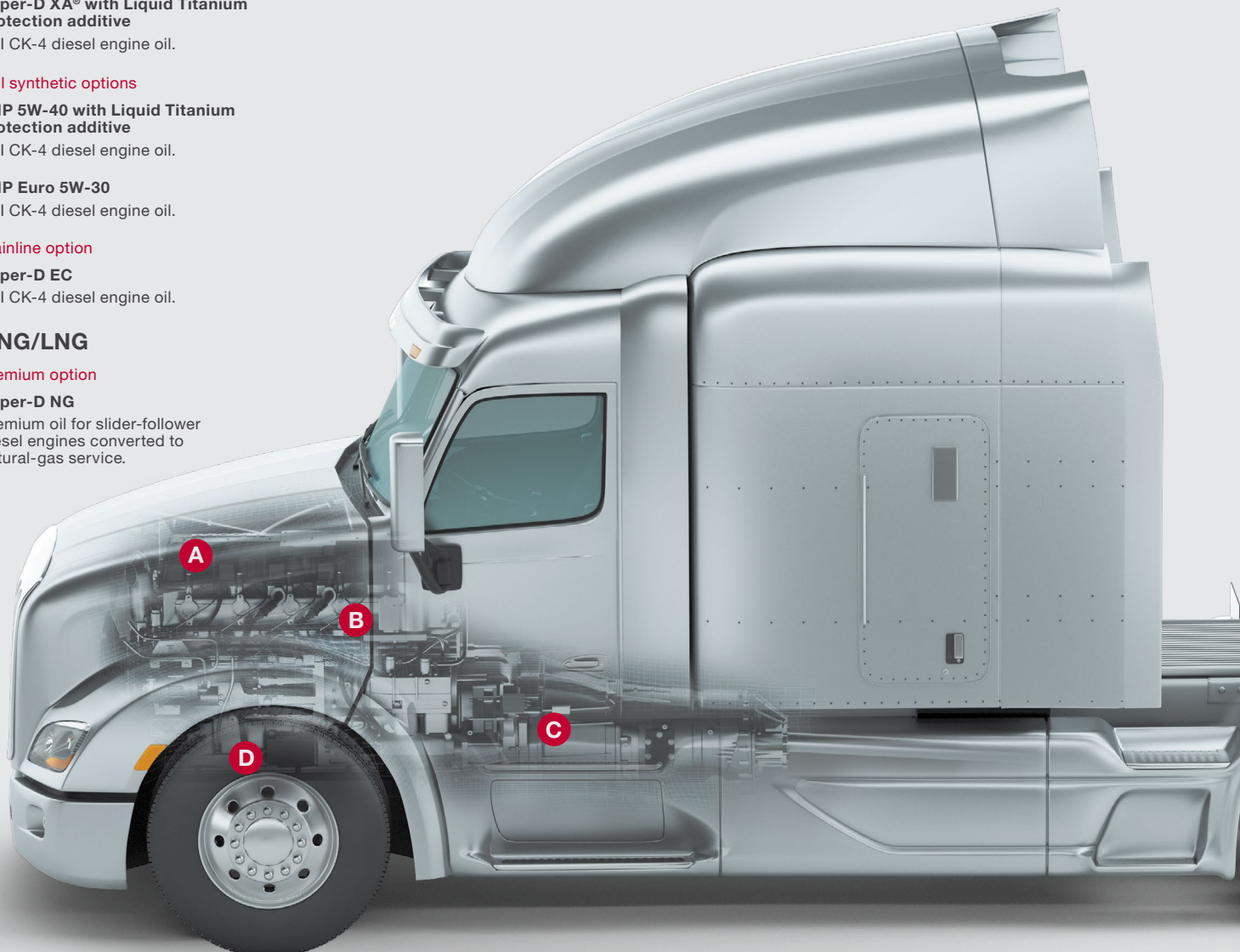

One million miles—and it's just getting broken in. It's our job to keep that truck on the road. With a complete line of Kendall® heavy-duty lubricants, we've got you covered—from headlights to trailer lights. All engineered to reduce engine wear, improve performance and provide smooth shifting. We're here to help keep those big wheels turning. Because we know you need to get another two million miles out of that rig before all's said and done.

TRANSMISSION

C MANUAL

Premium/long-drain option

SHP Synthetic Transoil 50

Full synthetic SAE 50 manual transmission fluid, API MT-1 for extended drain, all-season performance in trucks and buses.

Mainline option

Super-D 3 SAE 50

Heavy-duty monograde diesel engine oil for heavy-duty manual transmissions in trucks and buses.

AUTOMATIC

Allison

SHP HD ATF

Full synthetic, heavy-duty automatic transmission fluid for use in truck and bus transmissions operating under severe service or extended drain intervals.

SHP 295 ATF

Full-synthetic heavy duty automatic transmission fluid with outstanding low-temperature properties for year-round use in trucks and buses.

Voith, ZF

VersaTrans® ATF

Premium-quality synthetic blend fluid for automatic transmissions.

D STEERING AXLE WHEEL BEARINGS

L-427 Super Blu® Grease

Versatile, multipurpose lithium grease for moderate temperatures and loads. For tie rod ends, kingpins, door hinges, etc.

E DIFFERENTIAL/FINAL DRIVE

Premium/long-drain option

SHP Synthetic Gear Lube or Super Three Star Synthetic Gear Lubricant

Synthetic multipurpose gear lubricants for truck axles with hypoid gear sets operating in normal to severe conditions.

Mainline option

NS-MP Hypoid Gear Lubricant

Multipurpose gear lubricant, API GL-5/MT-1, for truck axles and some heavy-duty manual transmissions in trucks and buses.

F CHASSIS GREASE POINTS

Normal to severe service

L-427 Super Blu Grease

Versatile, multipurpose lithium grease for moderate temperatures and loads. For tie rod ends, kingpins, door hinges, etc.

G FIFTH WHEEL GREASE

C-915 Fifth Wheel Grease

Calcium grease with 10% graphite for protection against wear in high load-carrying capacity operations.

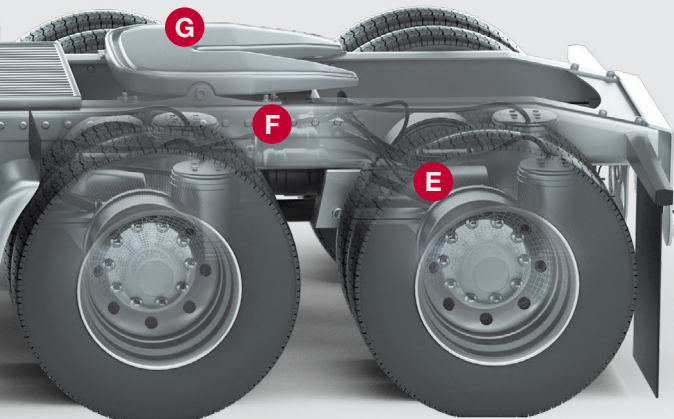

TRAILERS

Refrigeration units

Super-D XA with Liquid Titanium protection additive

Synthetic blend motor oil for enhanced thermal stability in all conditions.

Non-driven axles

Extended Bearing Life Grease

Semi-fluid polyurea grease developed for lubricating wheel bearings on non-driven truck trailer axles equipped with oil seals.

Assorted chassis

for normal to severe service

L-427 Super Blu Grease

Versatile, multipurpose lithium grease for moderate temperatures and loads. For slack adjusters, door hinges, etc.

CONSTRUCTION

A HYDRAULICS

Premium options

Hyken® Glacial Blu Hydraulic Fluid

High-quality, low-viscosity antiwear hydraulic oil for use in mobile equipment operating in cold climates. It has a high viscosity index and a low pour point.

Hyken Golden MV Hydraulic Fluid

High-quality, high-viscosity index antiwear hydraulic oil for industrial and mobile equipment operating in cold climates or in locations with wide temperature variations.

Mainline options

Powershift Transmission Fluid 10W-30

High-performance multifunctional fluid for transmissions, final drives and hydraulic systems where Caterpillar TO-4 requirements are specified.

Super-D® Mobile Hydraulic Fluid 10W

High-performance fluid for Caterpillar hydraulic systems and other off-highway mobile equipment, plus in hydrostatic transmissions of some off-road equipment.

Four Seasons Hydraulic Fluid AW

High-quality, antiwear hydraulic oil for use in a wide variety of mobile applications.

B GREASE POINTS

Premium option

SHP® Grease

Multipurpose, extreme pressure (EP) calcium sulfonate grease for use in equipment operating in wet or corrosive environments.

Mainline option

L-427 Super Blu® Grease

Multipurpose, extreme pressure (EP) lithium-complex grease for equipment operating under heavy loads at moderate to high temperatures.



It's your job to turn mountains into molehills. So, you bring out the heavy machinery to dig, scrape and bulldoze. Naturally, you expect a lot from your equipment. Putting it through the wringer knowing all too well that every minute of downtime costs you—something you can't afford. That's why you should count on Kendall® with heavy-duty lubricants specifically formulated to exceed the performance demands of your equipment. And real-world tested for the kind of rigorous work you put it through.

C DIFFERENTIALS AND AXLES

Mainline options

NS-MP Hypoid Gear Lubricant

API GL-5/MT-1 gear lubricant for axles with hypoid gear sets and some heavy-duty manual transmissions.

Powershift Transmission Fluid 50

High-performance multifunctional fluid for differentials, final drives and heavy-duty manual transmissions where Caterpillar TO-4 requirements are specified.

D ENGINE

Premium option

Super-D XA® 15W-40 with Liquid Titanium® protection additive

API CK-4 synthetic blend diesel engine oil with exclusive wear protection.

Mainline options

Super-D EC 15W-40

API CK-4 diesel engine oil.

Super-D 3 15W-40

API CI-4 Plus universal fleet oil.

E TRANSMISSION

Powershift Transmission Fluid 10W-30

Multipurpose fluid for equipment requiring one lubricant for the transmission, final drive, wet brakes and hydraulic systems.

Super-D Mobile Hydraulic Fluid 10W

High-performance fluid for Caterpillar hydraulic systems and other off-highway mobile equipment, plus hydrostatic transmissions of some off-road equipment.



SPECIALTY

Arctic applications

SHP Arctic 0W-40

Premium full synthetic diesel engine oil for use where the low-temperature properties of an SAE 0W-40 is required.

AGRICULTURE

A HYDRAULICS

Premium option

Hyken® 052 Plus Farm Tractor Lubricant

Multipurpose shear-stable fluid for farm tractors and equipment requiring one lubricant for the transmission, final drive, wet brakes and hydraulic systems.

Mainline options

Hyken 052 Farm Tractor Lubricant

Multipurpose fluid for farm tractors and equipment requiring one lubricant for the transmission, final drive, wet brakes and hydraulic systems.

Powershift Transmission Fluid 10W

High-performance multifunctional fluid for transmissions, final drives and hydraulic systems (Cat TO-4 approved).

C DIFFERENTIALS AND AXLES

Premium option

Hyken 052 Plus Farm Tractor Lubricant

Multipurpose shear-stable fluid for farm tractors and equipment requiring one lubricant for the transmission, final drive, wet brakes and hydraulic systems.

Mainline options

Hyken 052 Farm Tractor Lubricant

Multipurpose fluid for farm tractors and equipment requiring one lubricant for the transmission, final drive, wet brakes and hydraulic systems.

NS-MP Hypoid Gear Lubricant

Multipurpose API GL-5/MT-1 gear lubricant for axles with hypoid gear sets.

B GREASE POINTS

Premium option

SHP® Grease

Multipurpose, extreme pressure (EP) calcium sulfonate grease for use in equipment operating in wet or corrosive environments.

Mainline option

L-427 Super Blu® Grease

Multipurpose, extreme pressure (EP) lithium complex grease for equipment operating under heavy loads at moderate to high temperatures.

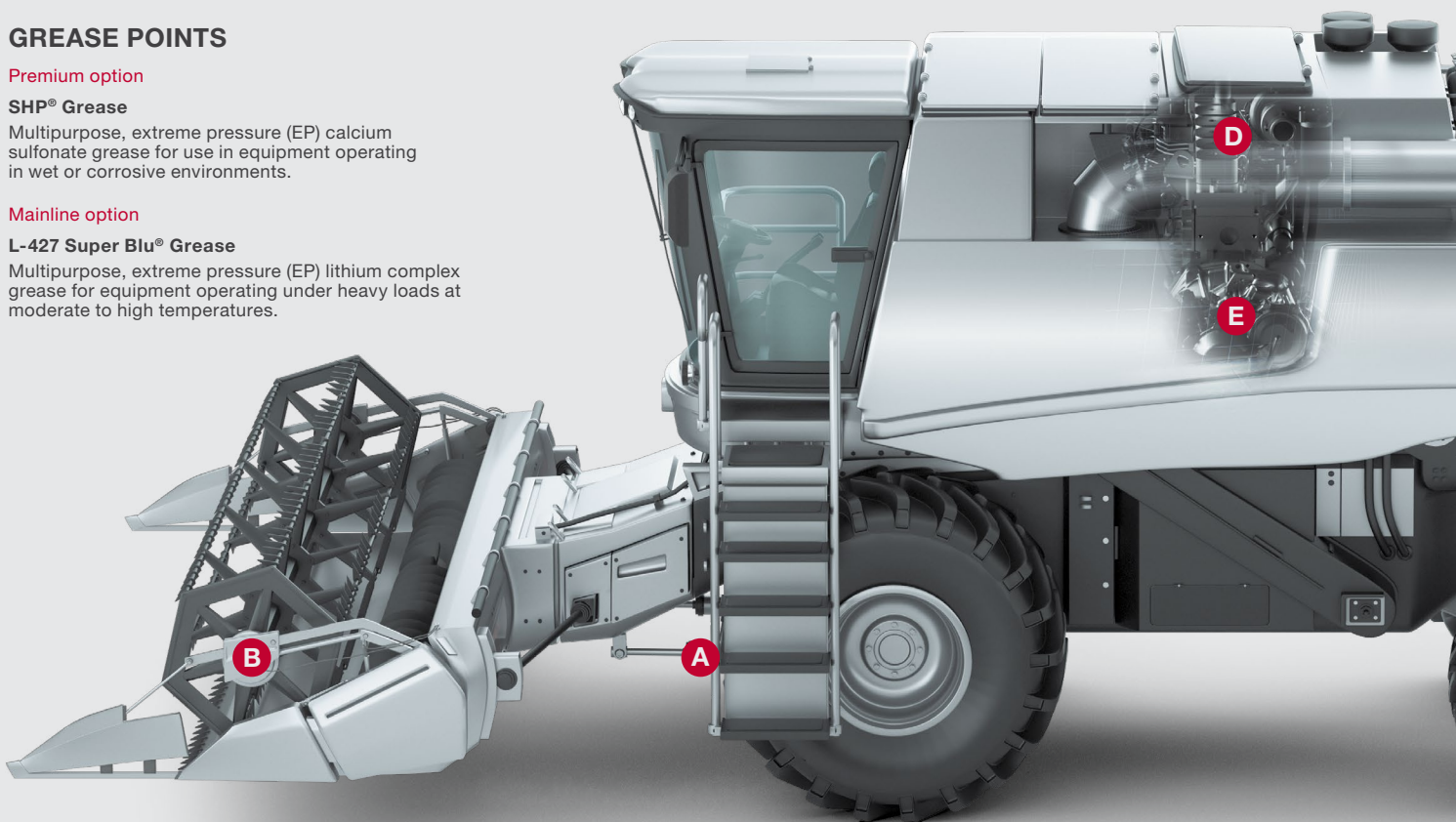

As if your job isn't hard enough. There's the rain, the snow, the scorching summers and bone-chilling winters. It's brutal on your equipment. What you don't need is any doubt your combine and tractor will start, and run like a champ every morning. That's why you need heavy-duty lubricants you can count on like Kendall,[®] developed and formulated for the extreme demands your ag equipment endures. And field-tested for ultimate performance and reliability.

D ENGINE CRANKCASE

Premium option

Super-D XA[®] 15W-40 with Liquid Titanium[®] protection additive

Synthetic blend API CK-4 diesel engine oil with exclusive wear protection.

Mainline options

Super-D[®] EC 15W-40

API CK-4 fleet engine oil.

Super-D 3 15W-40

API CK-4 Plus engine oil for older equipment.

E TRANSMISSION

Premium option

Hyken 052 Plus Farm Tractor Lubricant

Multipurpose shear-stable fluid for farm tractors and equipment requiring one lubricant for the transmission, final drive, wet brakes and hydraulic systems.

Mainline option

Hyken 052 Farm Tractor Lubricant

Multipurpose fluid for farm tractors and equipment requiring one lubricant for the transmission, final drive, wet brakes and hydraulic systems.



SPECIALTY

Smaller HP, gasoline-powered equipment

GT-1[®] High Performance with LiquiTek[®]

Premium synthetic blend providing excellent engine protection under all operating conditions.

Implements with gear boxes requiring an AGMA EP gear lubricant

Industrial Gear Oil

Premium extreme pressure (EP) gear oil with "clean gear" additive technology.

Older tractors requiring API GL-1 gear lubricant

All-Oil Gear Lubricant

API GL-1 gear oil for use in manual transmissions, transfer cases, steering gear boxes and rear axles of farm and other off-highway equipment.

Equipment with dedicated hydraulic oil reservoir

Four Seasons Hydraulic Fluid AW

High-quality antiwear oil for use in a wide variety of mobile hydraulic system applications.

HEAVY-DUTY ENGINE OIL LINEUP

FULL SYNTHETIC



SHP®
Our premium-quality, full synthetic API CK-4 engine oil developed for use in four-stroke diesel engines operating under extreme temperature conditions.
5W-40



SHP FE
Our premium-quality, full synthetic API FA-4 engine oil developed for fuel economy benefits in 2017 and newer engines.
5W-30



SHP EURO
Our premium-quality, full synthetic API CK-4 engine oil developed for diesel engines operating under extreme temperature conditions.
5W-30



SHP ARCTIC
Our premium-quality, full synthetic API CK-4 engine oil developed for use in four-stroke cycle diesel engines operating under arctic temperature conditions.
0W-40

Every one of our heavy duty engine oils, from CK-4 to FA-4, is proven to resist viscosity and thermal breakdown — even under the most extreme conditions. Due to the lubricant power packed in each iconic bright-red bottle, you get maximum protection against oxidation, along with long-lasting wear and corrosion resistance. Basically, it comes down to this: When you choose Kendall® Motor Oil for your hardworking fleet, you choose longer engine life and a more efficient and productive operation.

SYNTHETIC BLEND



Super-D XA®
Our premium-quality, synthetic blend API CK-4 engine oil with Liquid Titanium® protection additive. Designed for use in new and older diesel engines.
10W-30 | 15W-40



Super-D® FE
Our premium-quality, synthetic blend API FA-4 engine oil developed for fuel economy benefits in 2017 and newer engines where FA-4 is specified.
10W-30

MARKET GENERAL



Super-D EC
Our premium-quality, API CK-4 engine oil developed for low-emission engines with four-stroke cycle diesel engines designed to meet 2007 and later EPA on-highway exhaust emissions standards.
10W-30 | 15W-40



TRANSMISSION FLUID & HYDRAULIC FLUID

TRANSMISSION FLUID



Powershift Transmission Fluid

High-performance multifunctional fluid for transmissions, final drives and hydraulic systems (Cat TO-4 approved).



SHP® Heavy Duty

This premium synthetic ATF has excellent shear stability and high load-carrying ability to protect against viscosity breakdown and wear. Provides performance capability comparable to the Allison TES-295 specification.



SHP Synthetic MTF

Our full synthetic, fuel-efficient transmission lubricant designed for use in heavy-duty commercial manual transmissions operating in extreme temperatures and/or extended service intervals.



Hyken® 052 Plus Tractor Lubricant

Multipurpose shear-stable fluid for modern farm tractors and equipment requiring one lubricant for the transmission, final drive, wet brakes and hydraulic systems.



Hyken 052 Farm Tractor Lubricant

Our multifunctional fluid formulated for use in farm tractors and other off-highway equipment requiring one lubricant for the transmission, final drive, wet brakes and hydraulic systems.

Whether it's putting the muscle into your end loader or keeping that combine purring smoothly, Kendall® has the heavy-duty hydraulic lubrication your equipment demands. And every product is designed to perform under the relentless pressure your equipment is slammed with every day. With so much riding on your hydraulic system, pouring maximum protection in your engine is critical to overall equipment performance.

HYDRAULIC FLUID



Four Seasons

Our high-quality antiwear hydraulic fluid developed for use in a wide variety of industrial and mobile hydraulic system applications.



Hyken Glacial Blu

Our high-quality low-viscosity antiwear hydraulic oil specially developed for use in industrial and mobile equipment operating at extremely low temperatures.



Super-D® Mobile Hydraulic Fluid

Our hydraulic fluid designed primarily for use in the hydraulic systems of Caterpillar and other off-highway mobile equipment. It also may be used in the hydrostatic transmissions of some off-road equipment.



Hyken Golden MV

Our high-quality, high viscosity index antiwear hydraulic oil developed for use in industrial and mobile equipment operating in cold climates or in locations subject to wide variations in ambient temperature.

GEAR OIL & GREASES

GEAR OIL



Super Three Star[®] Synthetic Gear Lubricant

Our full synthetic, API GL-5 gear lubricant specially designed for long-drain service and extended warranty protection in passenger car and truck axles with hypoid gear sets.



NS-MP Hypoid Gear Lubricant

Our multipurpose, API GL-5 gear lubricant specifically designed for use in passenger car and truck axles with hypoid gear sets.

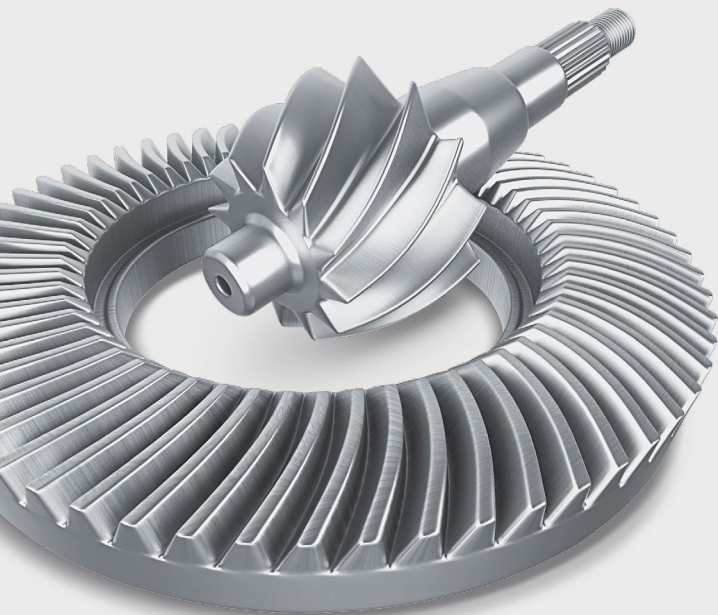

They say never trust a mechanic with clean hands. It's supposed to be a tough job. But to make your mechanic's life a little easier, Kendall® has developed a suite of heavy-duty greases and gear oils designed to keep your equipment rolling. Each product delivers excellent performance from axle to bearings, with environment-specific formulations that protect against corrosives, excel in wet applications and stay strong under extreme pressure. Grease may not be glamorous, but literally nothing moves without it. That's why we put in the time to get each formulation right.

GREASES



L-427 Super Blu®

Our extreme pressure (EP) lithium-complex grease developed for the lubrication of automotive and industrial equipment operating under heavy loads and at moderate to high temperatures.



SHP® Grease

Our extreme pressure (EP) calcium sulfonate grease specially developed for use in industrial and automotive equipment operating in wet or corrosive environments.



C-915 Fifth Wheel Grease

Our smooth-textured calcium grease, with 10% graphite, specially developed to handle the severe loads associated with fifth wheel applications.



Extended Bearing Life Grease

Our semi-fluid, extreme pressure (EP) polyurea grease specially developed for the lubrication of wheel bearings on non-driven truck trailer axles equipped with oil seals.

**YOU GET OUT
WHAT YOU
PUT IN.**



To see the full line of Kendall® products visit KendallMotorOil.com. For more information, call our Technical Support Hotline at 1.877.445.9198.



© Phillips 66 Company. Kendall® and its respective logos and products are registered trademarks of Phillips 66 Company in the U.S.A. and other countries. BL-KEN-203101